



VZ-E Series High-voltage Vacuum Electromagnetic Contactors and Combination Units

MELVAC

High-performance, Environment-conscious Vacuum Electromagnetic Contactors



Safety & Quality



for a greener tomorrow

Eco Changes is the Mitsubishi Electric Group's environmental statement, and expresses the Group's stance on environmental management. Through a wide range of businesses, we are helping contribute to the realization of a sustainable society.

MITSUBISHI ELECTRIC CORPORATION
HEAD OFFICE: TOKYO BLDG., 2-7-3, MARUNOUCHI, CHIYODA-KU, TOKYO 100-8310, JAPAN

State-of-the-art Technologies Ensure High Performance and Ease of Use Introducing the Environment-conscious, Futuristically Designed VZ-E Series

The new VZ-E Series represents the latest step in the evolution of Mitsubishi Electric's line-up of Vacuum Electromagnetic Contactors (VMCs) and the pursuit of products that meet the diversifying needs of the era. From installation through maintenance, a new design and innovative technologies combine to enhance work efficiency and deliver superior reliability, safely protecting the power distribution equipment in factories, buildings and a wide range of other facilities.

INDEX

1 Type Selection.....	P2	7 Power Fuse Selection.....	P18
2 Ratings	P4	8 Related Tools and Devices	P20
3 External Dimensions	P6	9 Principles and Methods of Operation.....	P22
4 Connection Diagram.....	P14	10 Application Standards.....	P24
5 Standard Specifications and Accessories.....	P16	11 Placing an Order	P26
6 Optional Accessories	P17		



Type-P Fixed Contactor

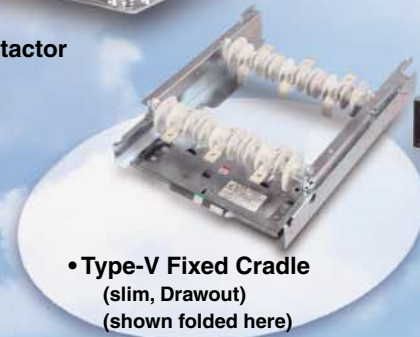

• Type-V Fixed Cradle (slim, Drawout) (shown folded here)



Type-V Combination Unit (slim, Drawout)



Type-C Combination Unit (standard, Drawout)



Type-D Combination Unit (bushing, Drawout)



Futuristic VMCs for Preserving the Environment

- No use of the six specified hazardous substances (i.e., mercury, cadmium, lead, hexavalent chromium, polybrominated biphenyls (PBBs), and polybrominated Diphenyl ethers (PBDEs)). In addition, small parts such as pins and screws are treated with an anti-corrosive agent free of hexavalent chromium, a soil contaminating substance.
- To facilitate recycling, the name of the material used is displayed on major plastic parts.



New Design Featuring Easy Installation, Simple Maintenance and Safe Operation

- The cradle is easier to pull out owing to the foldable structure adopted, thus reducing the time required for unpacking and installation (only available for types C/V with a rated current of 200A, and when a position switch is not installed).
- Low-friction resin with excellent sliding performance has been adopted for the bearing sections of three-phase axis. Furthermore, the sliding parts are coated with a long-life grease that contributes to the prevention of oxidization and deterioration.
- The mechanical holding latch has been replaced with a magnetic holding latch that uses a permanent magnet, thus eliminating the need for oiling of mechanical parts and reducing the time required for maintenance.
- The combination unit faceplate has a flat structure, allowing flexibility in the placement of parts such as the protective plate.
- Flame-retardant materials complying with UL94 (V-0) grade requirements are used in components such as the protection cover and main circuit terminal tube.
- The connection/test position detection switch and control circuit terminals come with a cover as standard equipment.
- Compliance with protection grade IP3X is available as an option (only types F/D [bushing, Drawout]).



High Reliability Supported by State-of-the-art Technologies

- Overload capacity has been increased (utilization category: AC3 to AC4 class), thus expanding the range of applications.
* Electrical endurance is AC3 class.
- Pursuit of the optimal structure, such as insulation design technology used for the vacuum valve, ensures the utmost reliability.
- Superior resistance to environmental factors has been realized, including mold materials with excellent anti-tracking performance.



Simplified Type Selection

- The operation counter and power fuse melting detector (combination unit only), which were optional in previous models, are now available as standard accessories.

1 Type Selection

External View of VZ-E Series Products

Fixed contactor

Fixed (Type-P)



Fixed combination unit

Fixed with caster (Type-G)



Drawout combination units

	Type-C main unit	Type-C cradle
Standard		
Bushing		
Thin		

System for Type Names

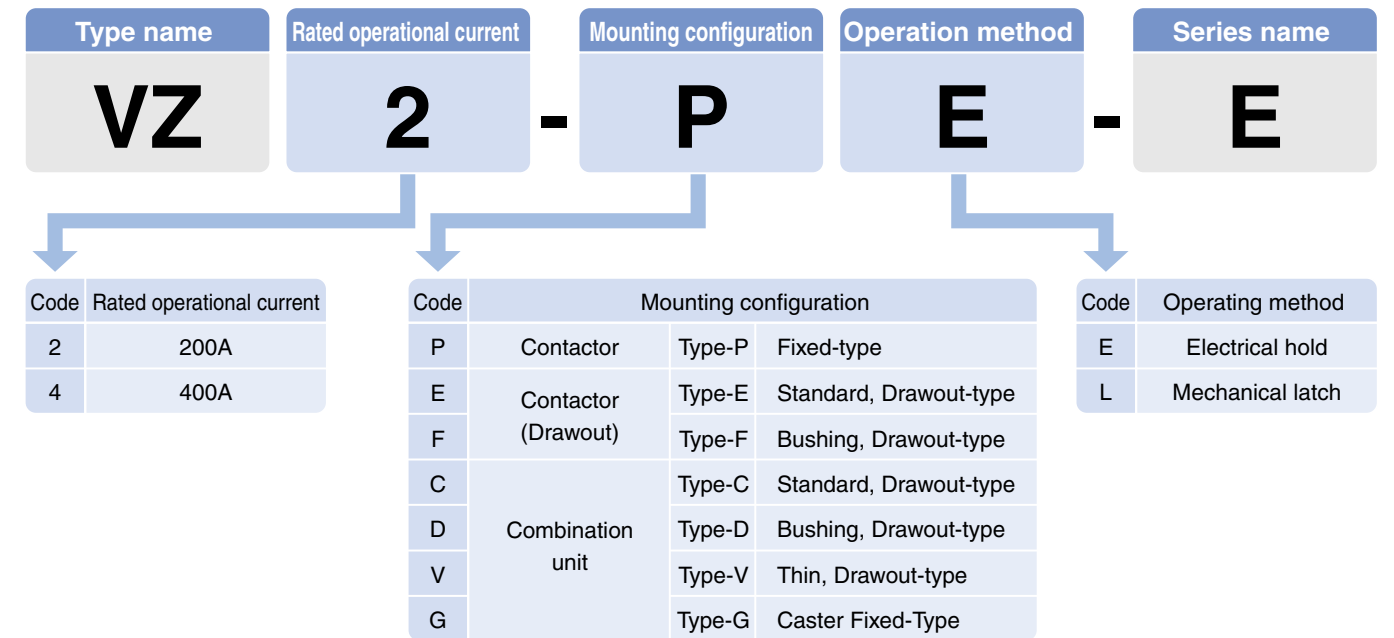

*The type name in the example above (VZ2-PE-E) is for the VZ-E Series continuous-excitation, fixed-type, 200A contactor.

*The thin, Drawout combination unit is limited to Types with a rated current of 200A.

Applicable Standards (Japan and International)

Applicable Standards for Contactors

Type	Rated voltage (kV)	Rated operational current (A)	Rated breaking current (kA)	Applicable standards			
				JEM1167 (2007)	IEC60470 (2000)	BS775-2 (1974)	NEMA ICS (1978)
VZ2-□E-E VZ2-□L-E	6.6/3.3	200	4			*1 ○	*1 ○
VZ4-□E-E VZ4-□L-E	6.6/3.3	400	4	○	○	{ 3.6kV 25MVA 7.2kV 25MVA 7.2kV 50MVA }	{ 2.3kV 17MVA 4.6kV 25MVA }

(○): Applicable standard

*1 Ratings are for the capacity listed.

List of Ratings

Item	Mounting configuration	Contactor							Contactor		Combination unit							
		Fixed-type				Drawout-type			Drawout-type		Drawout-type				Caster Fixed-Type			
Type		VZ2-PE-E	VZ2-PL-E	VZ4-PE-E	VZ4-PL-E	VZ2-EE-E VZ2-FE-E	VZ2-EL-E VZ2-FL-E		VZ4-EE-E VZ4-FE-E	VZ4-EL-E VZ4-FL-E	VZ2-CE-E VZ2-DE-E VZ2-VE-E	VZ2-CL-E VZ2-DL-E VZ2-VL-E	VZ4-CE-E VZ4-DE-E	VZ4-CL-E VZ4-DL-E	VZ2-GE-E	VZ2-GL-E	VZ4-GE-E	VZ4-GL-E
Rated operational voltage JEM	(kV)	6.6/3.3 (common use)							6.6/3.3 (common use)		6.6/3.3 (common use)		6.6 exclusive 3.3 exclusive		6.6/3.3 (common use)		6.6 exclusive 3.3 exclusive	
Rated voltage IEC	(kV)	7.2/3.6 (common use)							7.2/3.6 (common use)		7.2/3.6 (common use)		7.2 exclusive 3.6 exclusive		7.2/3.6 (common use)		7.2 exclusive 3.6 exclusive	
Rated insulation voltage JEM	(kV)	7.2							7.2		7.2							
Rated operational current	(A)	200		400		200			400		200		400		200		400	
Rated frequency	(Hz)	50/60							50/60		50/60							
Short-circuit breaking current JEM	(kA)	4							4		40 (power fuse)							
Rated short-circuit breaking current IEC																		
Short-time withstand current JEM	(kA-s)	4-2		4-10, 8-0.5		4-2			4-10, 8-0.5		4-2		4-10, 8-0.5		4-2		4-10, 8-0.5	
Rated short-time withstand current IEC																		
Half-wave conduction current	(kAp)	33		60		33			60		33		60		33		60	
Operation method		Electrical hold	Mechanical Latch	Electrical hold	Mechanical Latch	Electrical hold	Mechanical Latch		Electrical hold	Mechanical Latch	Electrical hold	Mechanical Latch	Electrical hold	Mechanical Latch	Electrical hold	Mechanical Latch	Electrical hold	Mechanical Latch
Rated making/Breaking capacity (Utilization category) ^{*1}		AC4 (rated operational current 10 [closing] 8 [breaking])							AC4 (rated operational current 10 [making] 8 [breaking])		AC4 (rated operational current 10 [making] 8 [breaking])							
Operating cycles	(Times/hour)	600							600		600							
Electrical endurance	(Millions of times)	0.25 (AC3)							0.25 (AC3)		0.25 (AC3)							
Mechanical endurance	(Millions of times)	2.5	0.25	2.5	0.25	2.5	0.25		2.5	0.25	2.5	0.25	2.5	0.25	2.5	0.25	2.5	0.25
Rated withstand voltage (kV)	Short-duration power-frequency JEM	22							22		22							
	Short-duration power-frequency IEC	20							20		20							
	Lightning impulse	60 (between VI terminals: 40 [IEC])							60 (between VI terminals: 40 [IEC])		60 (between VI terminals: 40 [IEC])							
Maximum applicable capacity ^{*5}	Three-phase induction motor (kW)	3.3kV	750		1500		750		1500		750		1500		750		1500	
		6.6kV	1500		3000		1500		3000		1500		3000		1500		3000	
	Power distribution transformer (kVA)	3.3kV	1000		2000		1000		2000		1000		2000		1000		2000	
		6.6kV	2000		4000		2000		4000		2000		4000		2000		4000	
	Static capacitor (kVar) ^{*2}	3.3kV	750		1200		750		1200		750		1200		750		1200	
		6.6kV	1500		2000		1500		2000		1500		2000		1500		2000	
Main unit mass ^{*3} (excluding VT)	(kg)	17		18		27			28		43		For 6kV models: 54 For 3kV models: 43		40		For 6kV models: 52 For 3kV models: 41	
Cradle mass	(kg)								Type-E: 10 Type-F: 17		Type-C: 12 Type-D: 19 Type-V: 10		Type-C 6kV: 14 Type-C 3kV: 12 Type-D 6kV: 20 Type-D 3kV: 19					
Compatible power fuse rated current Mitsubishi Electric types CL (LB, -) and CLS- (R)	(A)										G5~G200 M20~M200 7.2kV for Type-V {Cannot install M100~ M200 power fuse}		G300, G400, M300, M400 for 3.6kV.*4 M300, M400 for 7.2kV.		G5~G200 M20~M200		G300, G400, M300, M400 for 3.6kV.*4 M300, M400 for 7.2kV.	
Compliance standards		JEM 1167 (2007)/IEC60470 (2000)							JEM 1167 (2007)/IEC60470 (2000)									

*1: Can also be used for capacitor switching (AC6b).

*2: The maximum total capacity of the VMC and load to which the series reactor (6%-13%) is connected. The figures are for when no parallel capacitor is connected.

*3: Includes the mass of the maximum-rating power fuse. The mass of one VT is 10kg. Two VTs is 20kg.

*4: Using power fuses with capacities of 200A or less for drawer combination units with a rating of 400A, the unit will be manufactured to the external dimensions of the unit rated for 200A (after delivery of the unit, it is structurally impossible to use 300A or 400A power fuses in the unit).

*5: Depending on the power fuse rating, there may be some ranges where it is impossible to synchronize VMC operation with a power fuse blowout. For applications requiring the VMC operation to be fully synchronized with a power fuse blowout, please select equipment (VMC/VCB) with a large switching capacity.

Drawout-type Combination Units (Thin)

Main unit

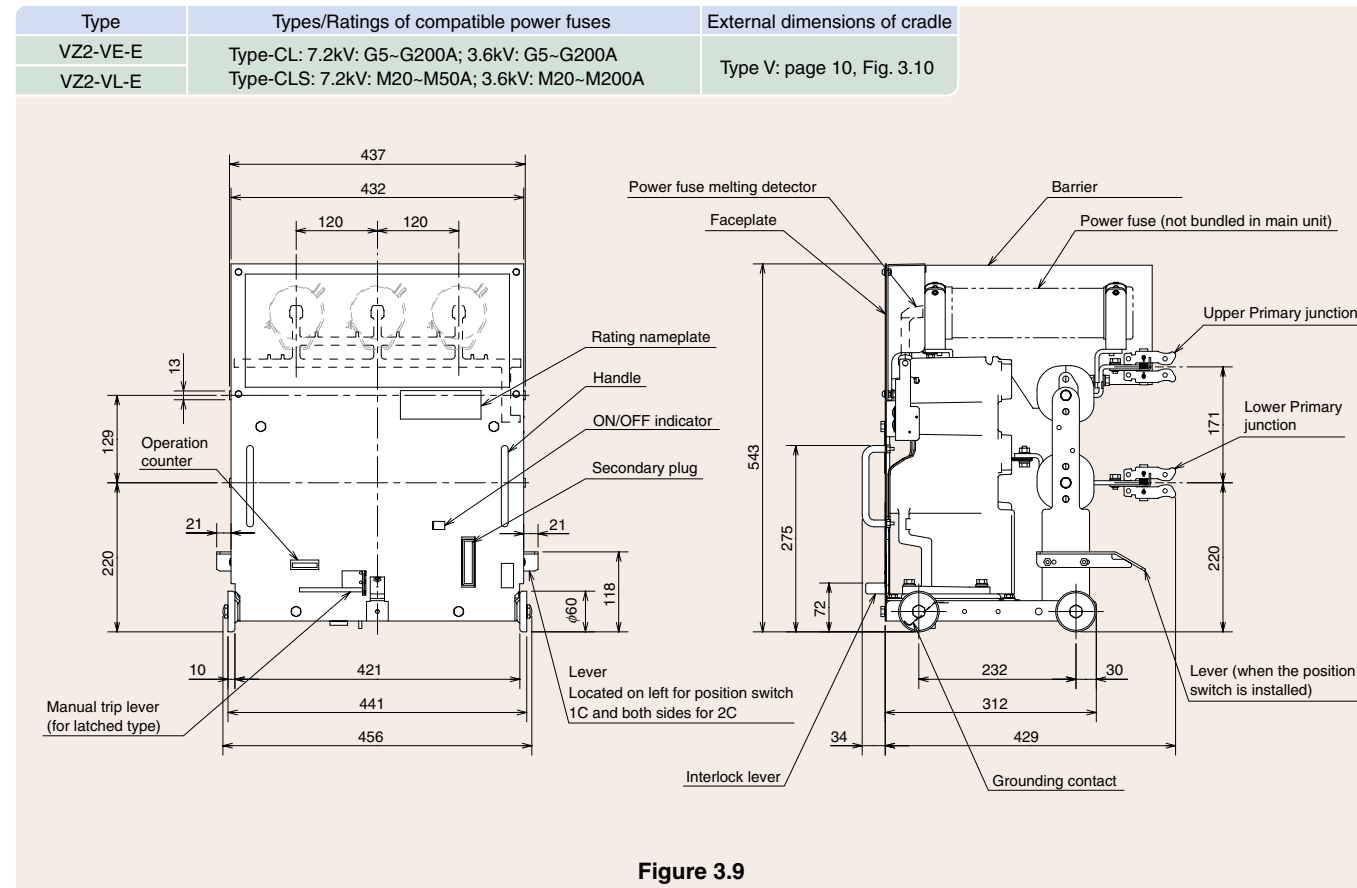

Fixed type Combination Unit (Caster Fixed-Type)

6.6/3.3kV, 200/400A Ratings (compatible with power fuses of 200A or less)

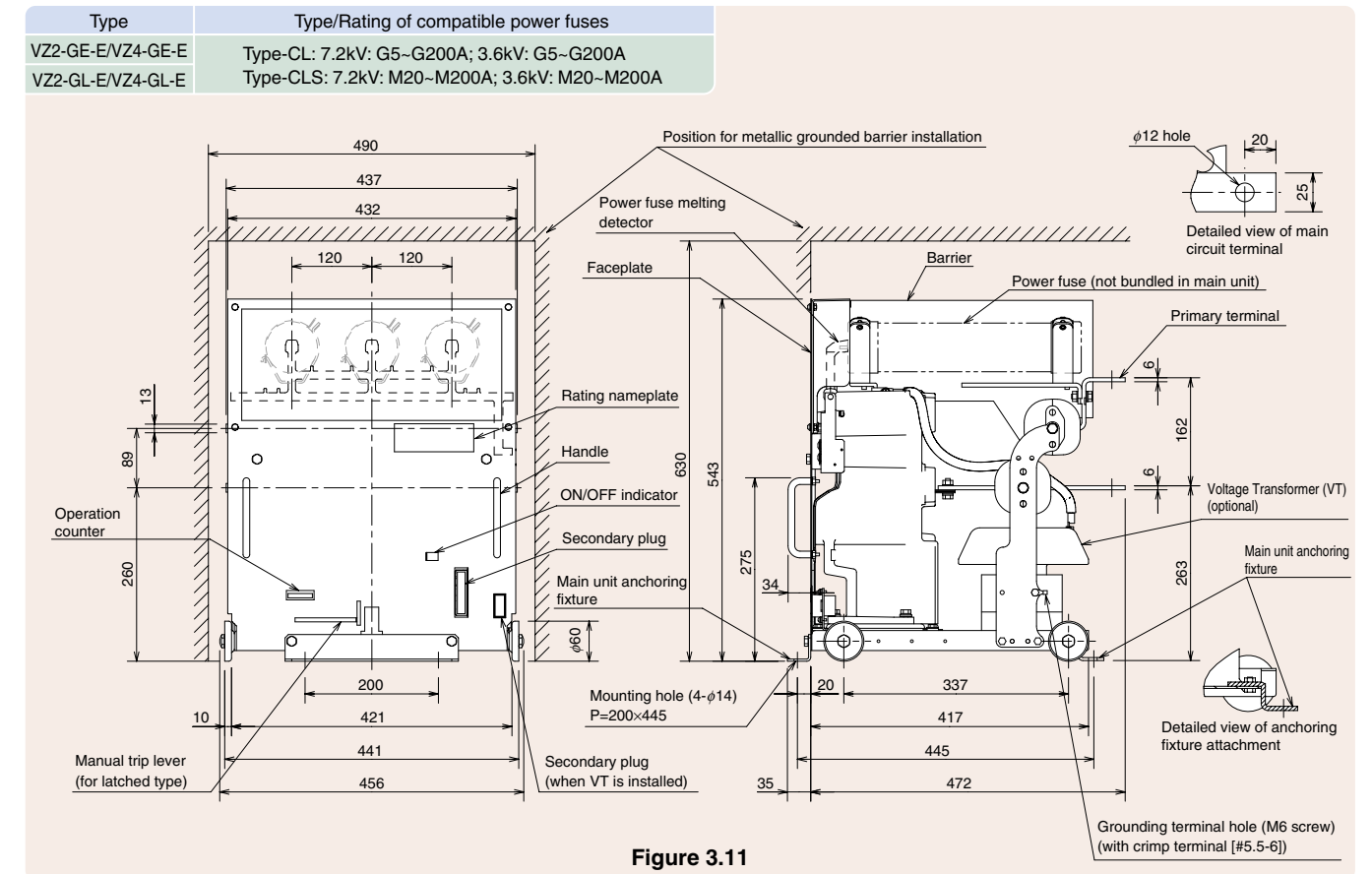

Cradles

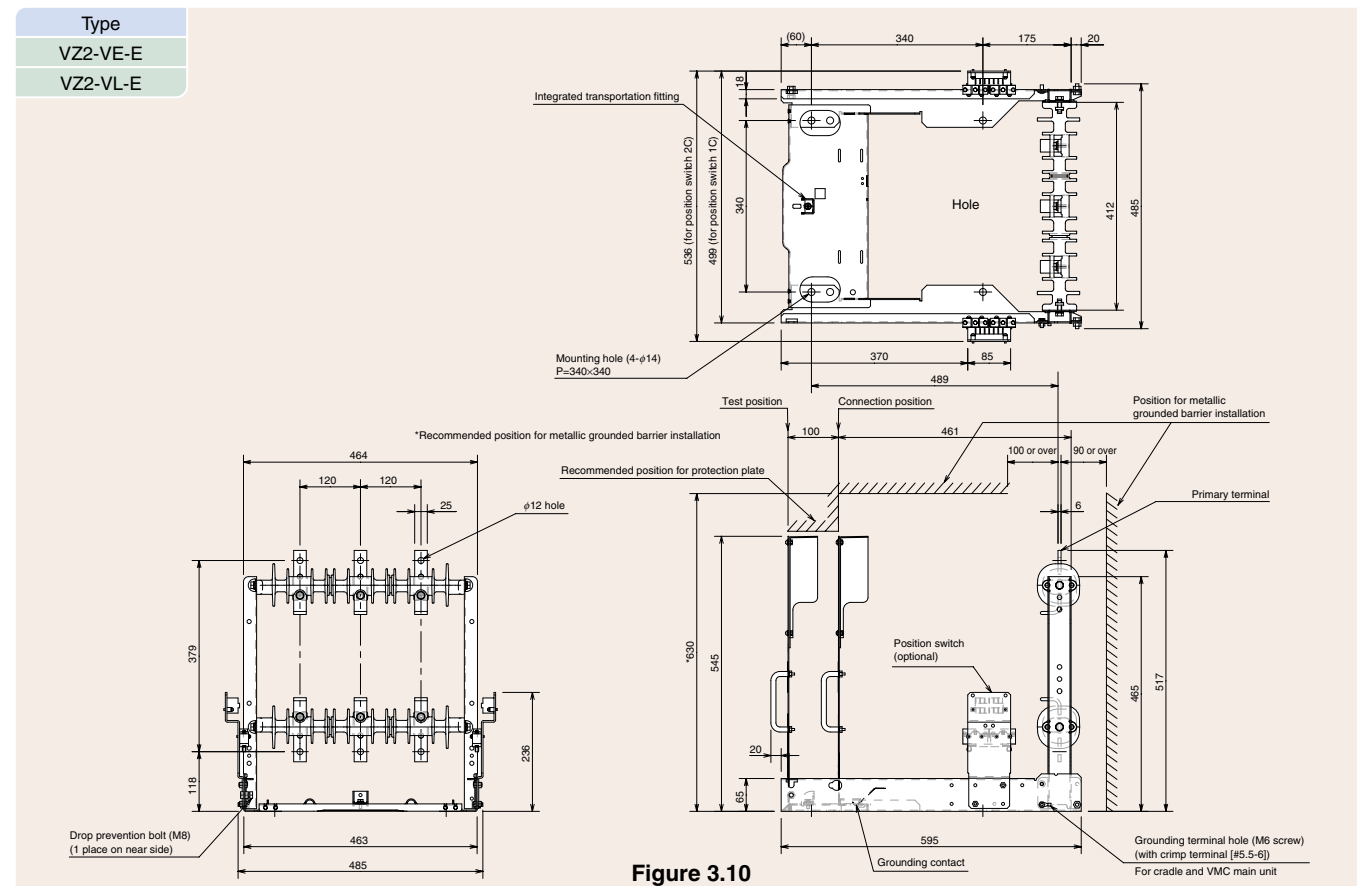

6.6/3.3kV, 400A Ratings (compatible with 300/400A power fuses)

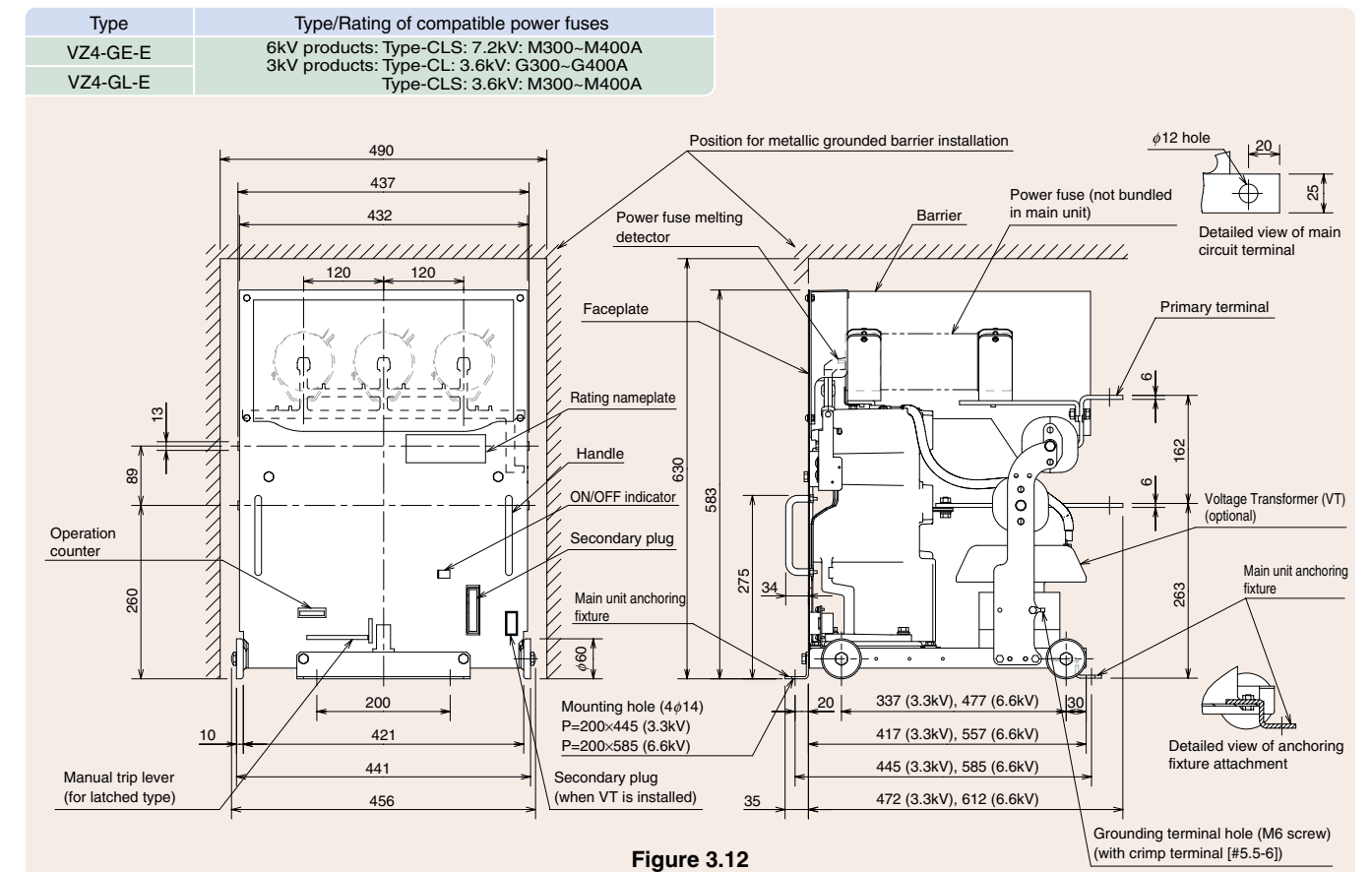

Drawout-type Contactor Main Unit (Standard/Bushing)

6.6/3.3kV, 200/400A Ratings

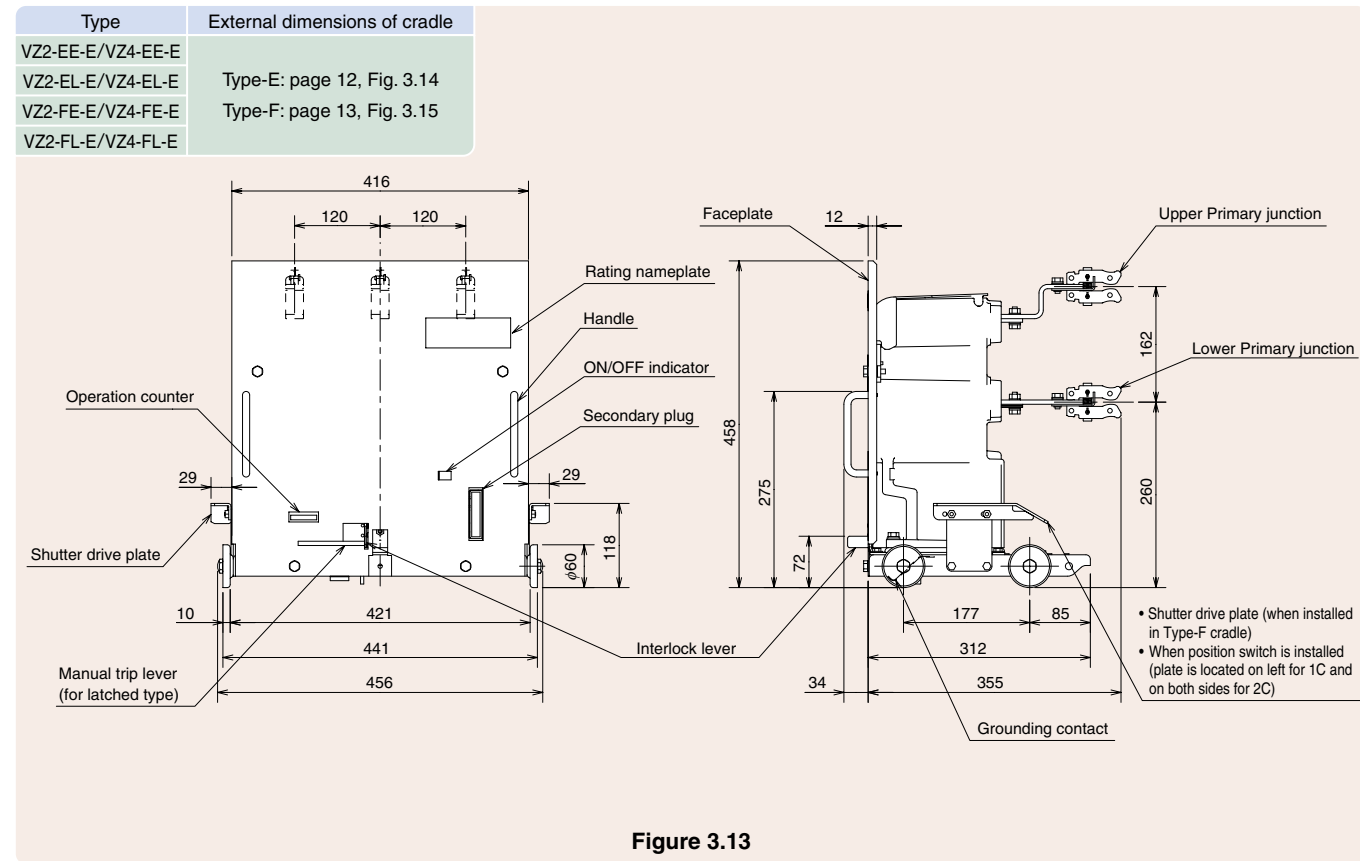

Drawout-type Contactor Cradle (Standard)

6.6/3.3kV, 200/400A Ratings

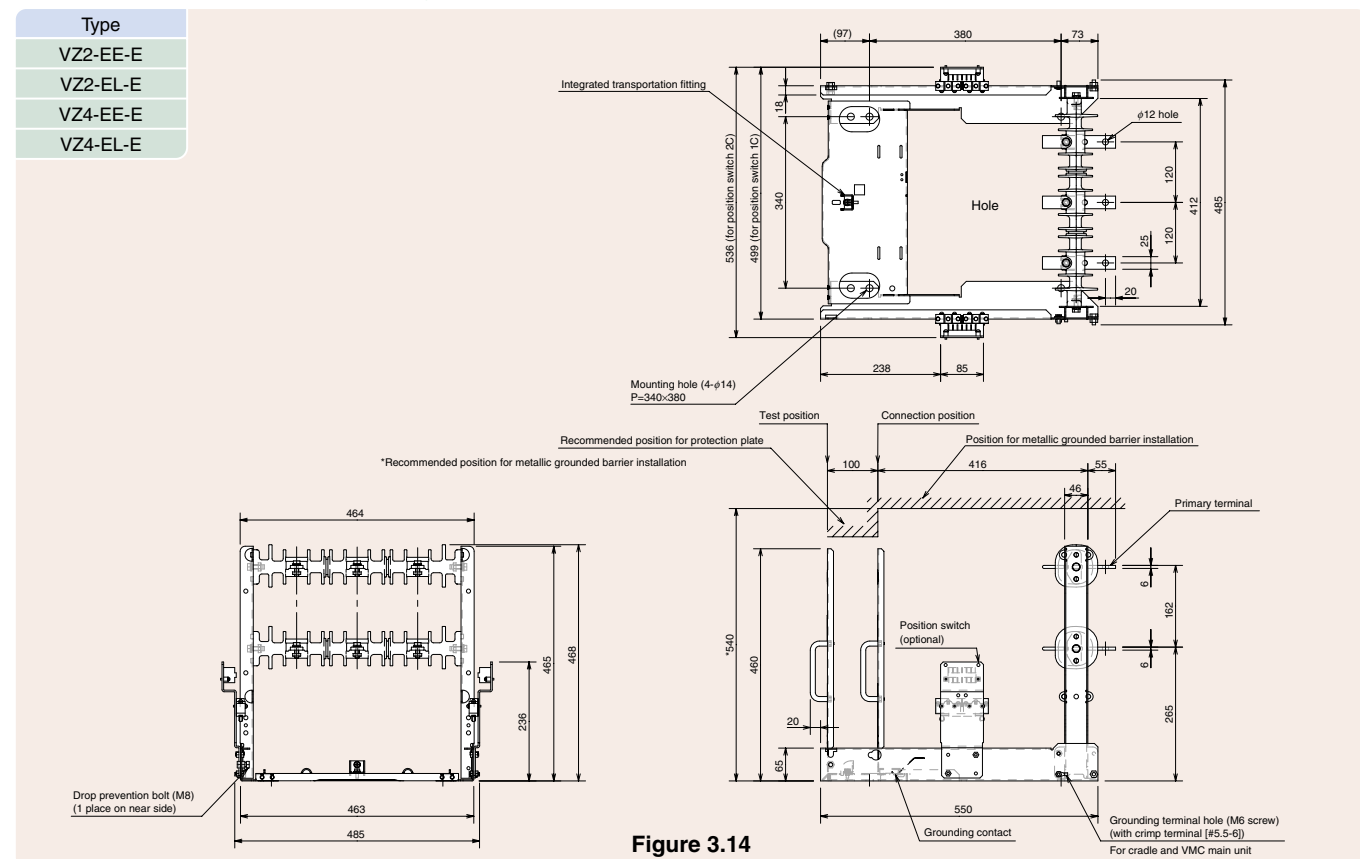

Drawout-type Contactor Cradle (Bushing)

6.6/3.3kV, 200/400A Ratings

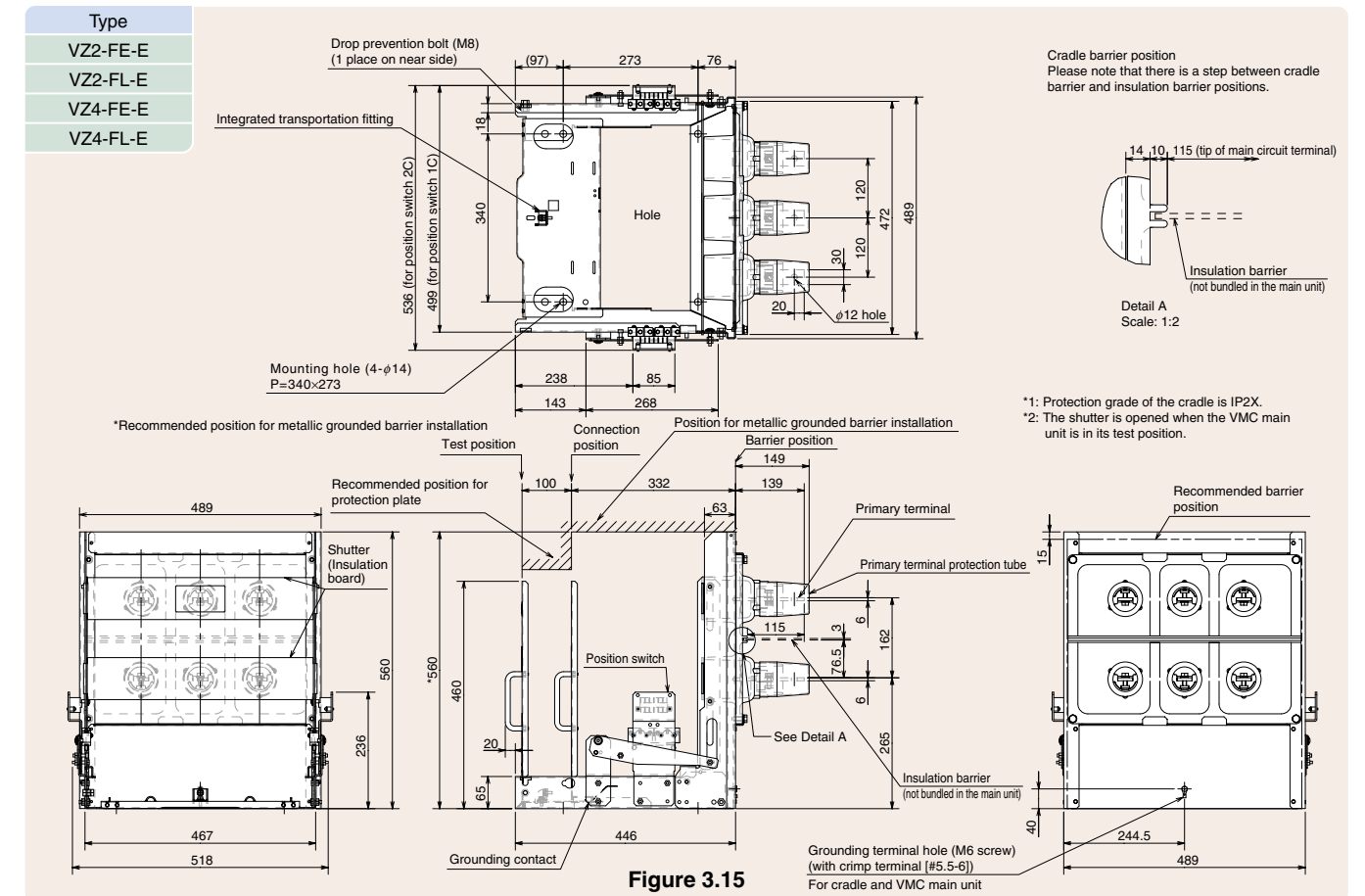

5 Standard Specifications and Accessories

Standard specifications for the VZ-E Series vacuum contactors and combination units are listed in Table 5.1. Please contact a Mitsubishi Electric representative for any special specifications (non-standard) you may need.

Standard Specifications

Table 5.1 Standard equipment

Standard equipment	Mounting configuration		Contactor				Combination unit				Application
	Type-P	Type-E	Type-F	Type-C	Type-D	Type-V	Type-G				
Main unit	Rating nameplate	○	○	○	○	○	○	○	JEM1167 (Japanese standard)/IEC60470(International standard)		
	Auxiliary switch	○	○	○	○	○	○	○	Number of contacts: 2a/2b		
	Operation counter	○	○	○	○	○	○	○	6-digit mechanical counter		
	Grounding terminal	○	-	-	-	-	-	○	Crimp contact (5.5m ² , M6 screw size)		
	Grounding contact	-	○	○	○	○	○	-	Automatically connect test and connection positions		
	Power fuse clamp	-	-	-	○	○	○	○	Five types of clamps are provided for different fuse ratings.		
	Power fuse melting detector	-	-	-	○	○	○	○	Number of contacts: 1a (fuse blowout monitored collectively for all 3 phases)		
	Insert/Drawer interlock device	-	○	○	○	○	○	-	Dual interlock (electrical and mechanical)		
	Shutter unit drive lever	-	-	○	-	○	-	-	One pair (one each at left/right side)		
	Cradle	Drop prevention bolt	-	○	○	○	○	○	-	One M8 bolt, near side on left	
Transportation fitting (integrated with main unit/cradle)		-	○	○	○	○	○	-	One M6 bolt, near side		
Grounding terminal		-	○	○	○	○	○	-	Crimp contact (5.5m ² , M6 screw size)		
Shutter unit		-	-	○	-	○	-	-	Insulation plate shutters (shutters at power supply/load sides are driven with same timing)		

*1: The symbol (○) indicates standard equipment.

*2: When you need a nameplate in English, please indicate the applicable standard.

*3: We cannot add or change combinations of auxiliary contacts. For applications requiring more contacts, please use the auxiliary relay, etc.

*4: Power fuses are sold separately.

Auxiliary Switch and Power Fuse Blowout Detection Switch Ratings

Table 5.2 Auxiliary switch ratings

Rated insulation voltage (V)	600		
Rated operational current (A)	AC220V	1	pf = 0.6 or more
	DC110V	1	L/R = 10ms or less
	DC220V	0.5	L/R = 40ms or less
Rated current-carrying capacity (A)	1		
Minimum operational current (A)	24V	0.05	
	100V	0.015	
Withstand voltage	Voltage applied between terminals (between poles)	power frequency withstand voltage	Lightning impulse withstand voltage
	Terminal and grounding	2kV	7kV
	Terminals (between poles)	—	3kV

*1: Please install a surge protector if there is a possibility that the on/off surge voltage in the relay will exceed the above withstand voltage.

*2: Do not operate the switch at currents lower than the minimum operating current, as this may cause a contact failure.

Standard Accessories

Table 5.4 List of standard accessories

Standard equipment	Mounting configuration		Contactor				Combination unit				Application
	Type-P	Type-E	Type-F	Type-C	Type-D	Type-V	Type-G				
Primary terminal protection tube	○	-	○	-	○	-	-	6 per unit			
Lead wires with connectors	○	○	○	○	○	○	○	1 per unit (1.25mm ² , yellow, 1.5m)			
Power fuse rating sticker	-	-	-	○	○	○	○	1 per unit			
Main unit fixture	-	-	-	-	-	-	○	1 pair (front and rear fixtures)/unit			
Insert/Drawer handle	-	○	○	○	○	○	-	1 per unit			

*Power fuse rating sticker is provided in a plastic bag together with the Instruction Manual and Test Report.

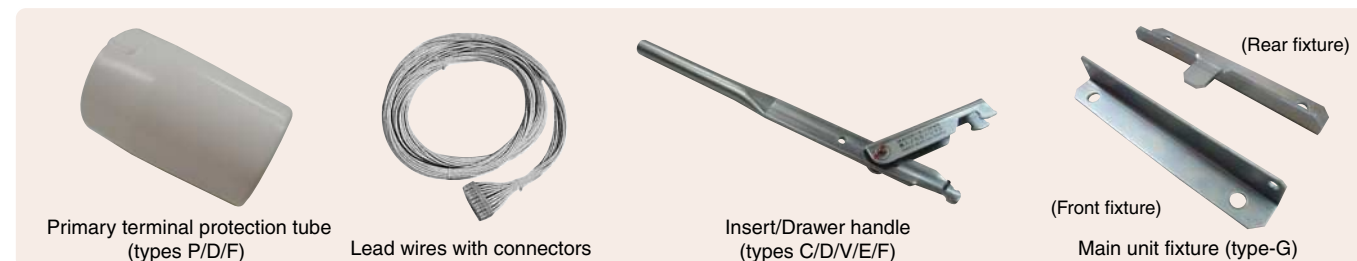

6 Optional Accessories

Optional accessories are listed in Table 6.1.

Accessories ordered will be installed in the contactor before delivery (excluding the control circuit terminal block).

Standard Specifications

Table 6.1 List of optional accessories

Name	Contactor			Combination unit				Application
	Type-P	Type-E	Type-F	Type-C	Type-D	Type-V	Type-G	
Control circuit terminal block	○	-	-	-	-	-	-	Secondary plug is connected to the terminal block (with 200mm cable)
Voltage transformer (VT)	-	-	-	○	○	-	○	Up to two VTs (50VA or 100VA) can be installed
Connection/Test position detection switch	-	○	○	○	○	○	-	1C/2C contacts can be installed for each connection/test position switch

Control Circuit Terminal Block

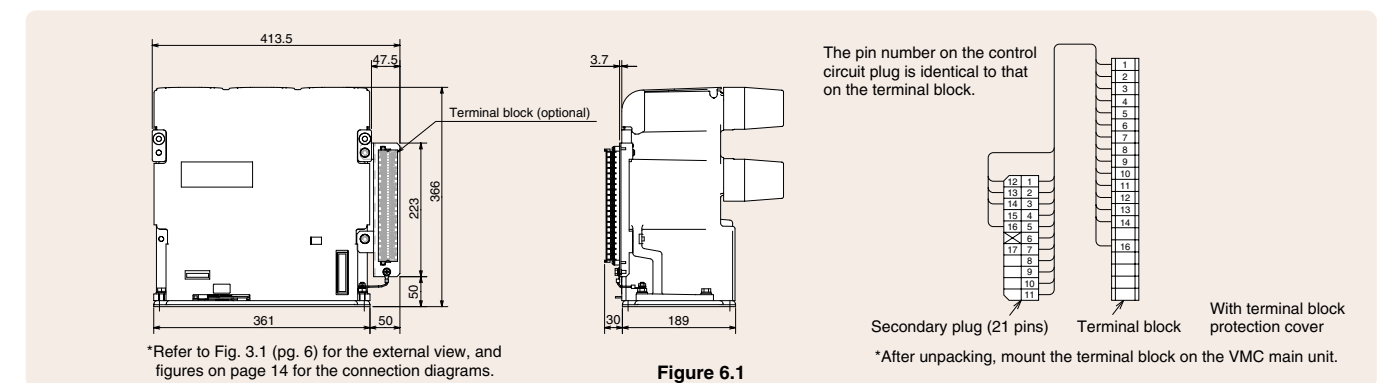

*Refer to Fig. 3.1 (pg. 6) for the external view, and figures on page 14 for the connection diagrams.

Figure 6.1

Voltage Transformer (VT)

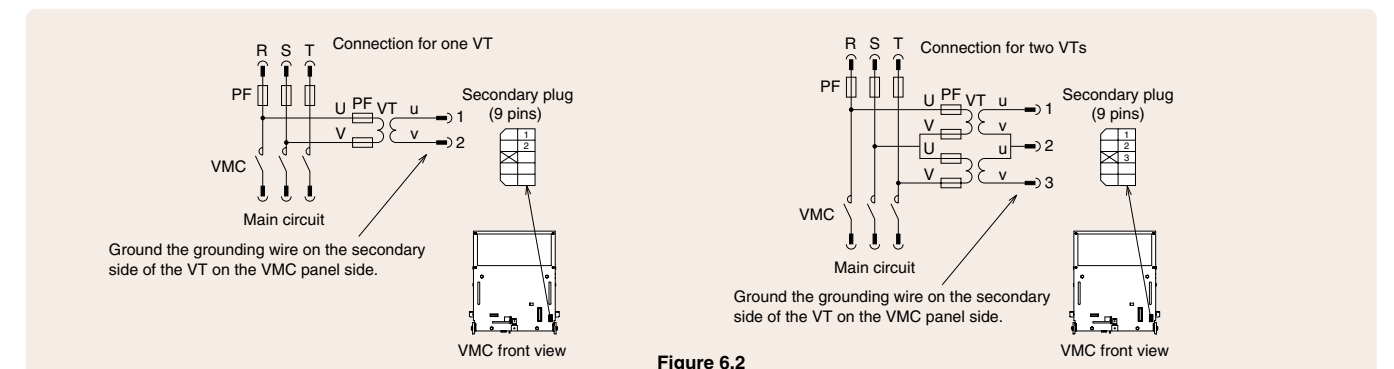

Figure 6.2

Connected/Test Position Detection Switch

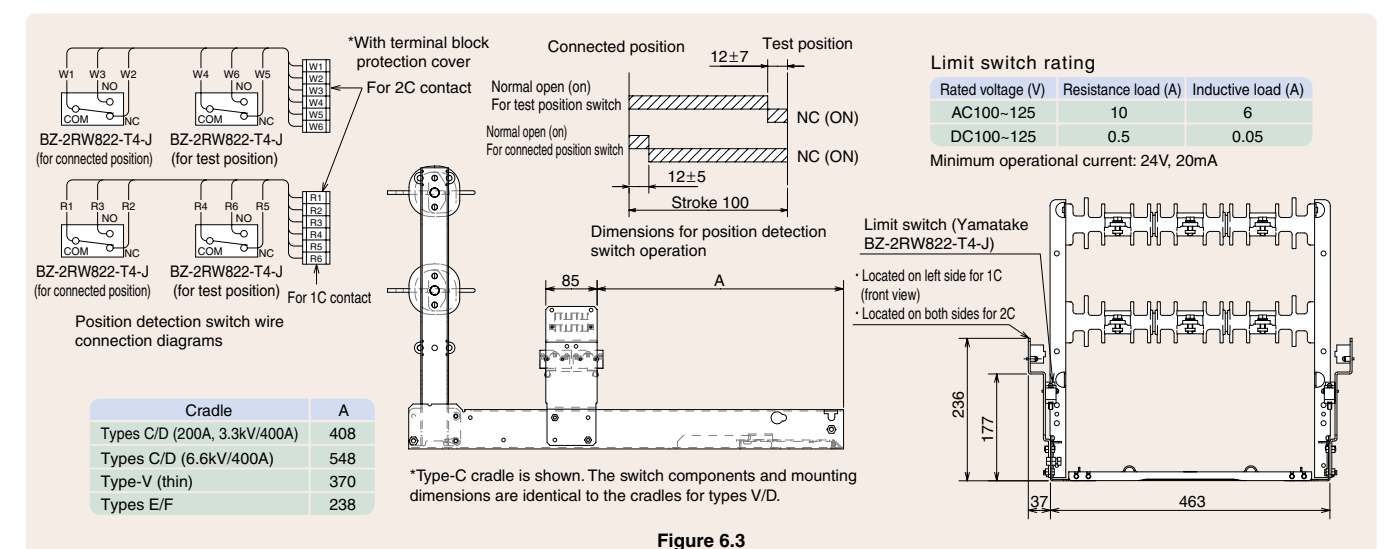

Figure 6.3

7 Power Fuse Selection

The short-circuit breaking current of the VZ-E Series VMCs is 4kVA. However, when combined with Mitsubishi Electric power fuses, application for short-circuiting up to 40kVA is possible.

When selecting a power fuse, please make sure to select a fuse that will not blow out due to inrush current from load equipment (e.g., motor starting current, transformer excitation/capacitor inrush currents). Tables 7.1 through 7.8 list the recommended power fuse current ratings for a variety of load equipment. For details on power fuses, please refer to the High-voltage/Ultrahigh-voltage Current-limiting Fuse Catalog.

Please note that, in general, the durability of electric switching varies from that of power fuses.

Motor Load

Table 7.1 3kV Three-phase induction motor

Motor output (kW)	Maximum applicable total load current (A)	Vacuum contactor rated operational current (A)	Power fuse (Type-CLS) rated current (A)
37~75	20	200	M20
90~200	50		M50
220~400	100		M100
450~630	150		M150
710~750	200		M200
900~1250	300	400	M300
1500	400		M400

● Mitsubishi Electric Type-CLS high-voltage, current-limiting fuse (Type No. R) is standard.

Table 7.2 6kV three-phase induction motor

Motor output (kW)	Maximum applicable total load current (A)	Vacuum contactor rated operational current (A)	Power fuse (Type-CLS) rated current (A)
75~160	20	200	M20
185~400	50		M50
450~800	100		M100
900~1250	150		M150
1500	200		M200
2500	300	400	M300
3000	400		M400

Transformer Load

Table 7.3 3kV Three-phase transformer

Transformer capacitor (kVA)	Transformer rated current (A)	Vacuum contactor rated operational current (A)	Power fuse (type-CL) rated current (A)		
			Minimum	Maximum	
5	0.87	200	G5 (T1.5)	G5 (T1.5)	
10	1.75		G10 (T3)	G10 (T3)	
20	3.50		G20 (T7.5)	G20 (T7.5)	G100 (T75)
30	5.25			G30 (T15)	
50	8.75		G30 (T15)	G50 (T30)	G20 (T150)
75	13.1			G75 (T50)	
100	17.5		G40 (T20)	G75 (T60)	
150	26.2		G50 (T30)		
200	35.0		G60 (T40)	G150 (T100)	
300	52.5		G75 (T60)		
500	87.5		G200 (T150)	*1—	
750	131		*1—		
1000	175		400	G400 (T300)	G400 (T300)
2000	350			*2—	*2—

● Mitsubishi Electric Type-CL high-voltage, current-limiting (Type No. and LB) is standard.

*1: CLS-R M200A power fuse is recommended (synchronizes with power fuse blowout).

*2: CLS-R M400A power fuse is recommended (G-rated product is not available).

*3: CLS-R M300A power fuse is recommended when combination unit used (G-rated product size is too large).

Capacitor Load

Table 7.5 3kV capacitor (without reactor)

Capacitor three-phase capacity (kVar) 50/60Hz	Capacitor rated current (A)	Vacuum contactor rated operational current (A)	Power fuse (Type-CL) rated current (A)	
			Minimum	Maximum
10 / 12	1.75	200	G10 (C3)	G50 (C30)
	2.10			
15 / 18	2.62			
	3.15			
20 / 24	3.50			
	4.20			
25 / 30	4.37		G20 (C7.5)	G100 (C60)
	5.25			
30 / 36	5.25			
	6.30			
50	8.75		G30 (C15)	
75	13.1			
100	17.5		G40 (C20)	

● For capacitors with a capacity of 150kVar or more, please make sure to install the series reactor.

Table 7.6 6kV capacitor (without reactor)

Capacitor three-phase capacity (kVar) 50/60Hz	Capacitor rated current (A)	Vacuum contactor rated operational current (A)	Power fuse (Type-CL) rated current (A)	
			Minimum	Maximum
10 / 12	0.87	200	G5 (C1.5)	G50 (C30)
	1.05			
15 / 18	1.31			
	1.57			
20 / 24	1.75			
	2.10			
25 / 30	2.19		G10 (C3)	G100 (C60)
	2.62			
30 / 36	2.62			
	3.15			
50	4.37		G20 (C7.5)	
75	6.56			
100	8.75		G30 (C15)	
150	13.1			
200	17.5		G40 (C20)	
250	21.9	G50 (C30)		

● For capacitors with a capacity of 300kVar or more, please make sure to install the series reactor.

Table 7.7 3kV capacitor (with "6-13%" reactor)

Capacitor three-phase capacity (kVar) 50/60Hz	Capacitor rated current (A)	Vacuum contactor rated operational current (A)	Power fuse (Type-CL) rated current (A)	
10 / 12	1.75	200	G5	
	2.10			
15 / 18	2.62			
	3.15			
20 / 24	3.50			
	4.20			
25 / 30	4.37		G10	G100 (C60)
	5.25			
30 / 36	5.25			
	6.30			
50	8.75		G20	
75	13.1			
100	17.5		G30	
150	26.2			
200	35.0		G50	G300
250	43.7			
300	52.5	G60		
400	70.0			
500	87.5	G75		
750	131			
1000	175	400	*4—	
1200	210		*7—	

● The capacity shown for the three-phase capacitor is the total capacity of the VMC and load including the reactor.

● Mitsubishi Electric Type-CL high-voltage current-limiting fuse (Type No. and LB) is standard. However, if circuit switching is frequent, the Type-CLS (Type No. R) fuse is recommended. Note that figures in the above tables are provided assuming that no parallel capacitor is connected.

*4: CLS-R M200 power fuse is recommended (to synchronize with power fuse blowout).

*5: CLS-R M200 power fuse is recommended (to synchronize with power fuse blowout).

*6: CLS-R M300A power fuse is recommended when the combination unit is used (G-rated product size is too large).

*7: CLS-R M400 power fuse is recommended (G-rated product is not available).

Table 7.4 6kV three-phase transformer

Transformer capacitor (kVA)	Transformer rated current (A)	Vacuum contactor rated operational current (A)	Power fuse (type-CL) rated current (A)		
			Minimum	Maximum	
5	0.44	200	—	—	
10	0.87		G5 (T1.5)	G5 (T1.5)	
20	1.75		G10 (T3)	G10 (T3)	G100 (T75)
30	2.62			G20 (T7.5)	
50	4.37		G20 (T7.5)	G50 (T30)	G20 (T150)
75	6.56			G40 (T20)	
100	8.75		G30 (T15)	G50 (T30)	G100 (T75)
150	13.1			G75 (T50)	
200	17.5		G40 (T20)	G100 (T75)	G200 (T150)
300	26.2			G50 (T30)	
500	43.7		G75 (T50)	G100 (T75)	
750	65.6			G200 (T150)	
1000	87.5		400	*1—	*1—
1500	131			*3 G400 (T300)	*3 G400 (T300)
2000	175		400	*2—	*2—
3000	262				
4000	350				

8 Related Tools and Devices

Related tools and devices are listed in Table 8.1.

These tools and devices are sold separately, and separate order for the tool(s) must be made (i.e., different order from that made for the vacuum contactor or combination unit).

Table 8.1 Related tools and devices

Name	Application
Capacitor tripping power supply device	Power device to trip the VMC when the control power is lost.
CR suppressor (surge absorption capacitor)	Surge protection during motor inching operation. Both 3kV and 6kV surge protectors are available. Note: Inching (energizing a motor or solenoid repeatedly for short periods to obtain small movements of the driven mechanism)
Vacuum checker	Portable tester used to verify vacuum strength. Both 100VAC and 200VAC testers are available.
Testing cables	Extension cables used for testing outside the panel. Both 2m and 4m cables are available.
Lifter (Type F-2C)	Tool to lift the VMC when VMC is inserted to or drawn from switchgear. Can be used with VF-8D/13D, VF-20D/25D, and VF-32D/40D.
Extension rail	Tool for easily lifting the VMC out of the panel (lifter commonly used).

Capacitor Tripping Device

Please make sure to specify the type and quantity when placing the order.

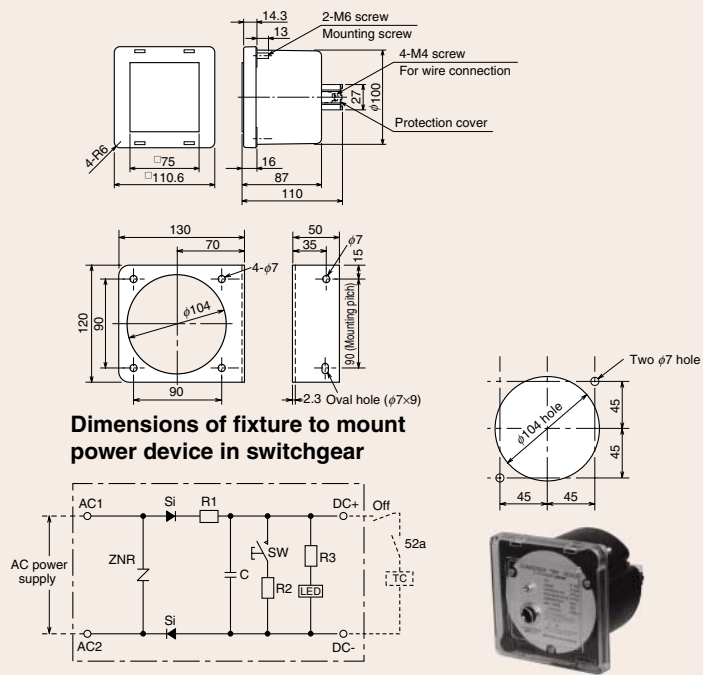

Dimensions of fixture to mount power device in switchgear

Circuit diagram (KF-100E/200E)

Figure 8.1 Capacitor tripping power device

List of constants

Type	Capacitor C	Resistance R1	Resistance R2	Resistance R3
KF-100E	820 μ F	10W300 Ω	10W100 Ω	0.5W240k Ω
KF-200E	220 μ F	10W600 Ω	10W200 Ω	0.5W1M Ω

Rating

Item	KF-100E	KF-200E
Rated operational voltage [V]	AC100/110	AC200/220
Rated frequency [Hz]	50/60	
Rated output voltage [V]	DC140/155	DC280/310
Power consumption (normal conditions) [W]	0.1	
Charging time constant [sec]	1	0.5
VMC control voltage [V]	AC100/110	AC200/220

Charging time constant (period of time required to charge a capacitor up to 63% voltage)

(Remarks)

- *1: It is standard to install the capacitor tripping power device within the switchgear.
- *2: No device-mounting fixture is included. The device-mounting fixture allows mounting of the device pointing left, right, up or down.

(Cautions)

- *1: Do not trip VMC before a capacitor is fully charged. Only apply a circuit open command after capacitor charging is complete.
- *2: Do not use this unit for any purpose other than VMC tripping.
- *3: One power supply device is required for each VMC.
- *4: The recommended renewal period is six years

CR Suppressor (Surge Absorption Capacitor)

Please make sure to specify the type and quantity when placing an order.

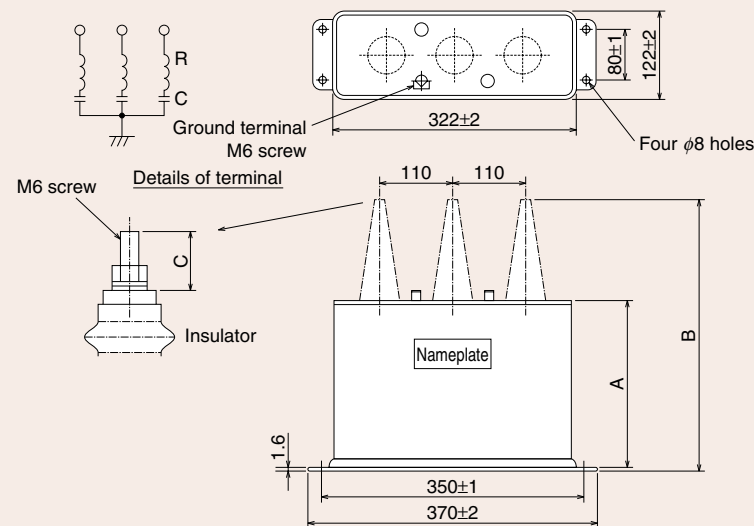

Figure 8.2 CR suppressor

Rating

Type	CR-3	CR-6
Operational voltage	3.3kV	6.6kV
External dimensions (mm)	A	150
	B	237
	C	16
Electrostatic capacity (μ F)	0.05 \times 3 phases	0.05 \times 3 phases
Resistance (Ω)	100 \times 3 phases	100 \times 3 phases
Weight (kg)	8.5	10

*Please make sure to disconnect wires before testing the withstand voltage.

*The recommended renewal period is 15 years

Handling instruction

(1) Caution about circuits that contain harmonics

Caution should be exercised when CR suppressors are applied to circuits that contain harmonics as is the case with general high-voltage capacitors. There are cases where multiorder harmonics may have flowed especially in circuits where current control is performed by means of thyristors. For use, the RMS value of the composite current containing harmonics should be the value in the following table (1.3 times the rated value) or less.

Type	CR-3	CR-6
Value of Allowable composite current containing harmonics	0.05 A RMS/phase	0.1 A RMS/phase

(2) Mounting direction

The mounting directions is vertical. Do not mount horizontally or use in an inverted position.

(3) Caution for periodic inspection

Make sure to ground when touching the high-voltage terminals of CR suppressors.

(4) Cautions for withstand voltage tests

- ① Perform withstand voltage tests after disconnecting wires.
- ② Pay attention to the voltage and applied time. There are cases where excessive current flows depending on the transformer capacity and withstand voltage tests cannot be performed. Generally, it is necessary to detach CR suppressors from circuits when withstand voltage test is performed in the condition that VCB has been inserted in a panel.

Allowable test voltage of CR suppressors

Rated test voltage	Type	AC	Type	
			CR-3	CR-6
			Between T and T	6.6kV
1 min	Between T and C	7.6kV	14.2kV	
	Between T and C	4.95kV	9.9kV	

T: Terminal C: Case

Vacuum checker

Please make sure to specify the type and quantity when placing an order.

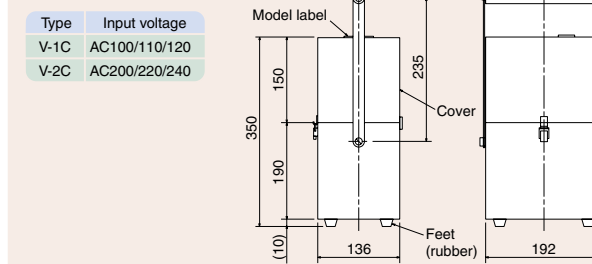

Figure 8.3 Vacuum checker

Testing cables

Please make sure to specify the type and quantity when placing an order.

Name	Length (L)	Application
Testing cables	2m	1.25mm ² , yellow
	4m	1.25mm ² , yellow

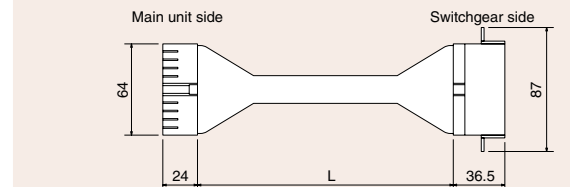
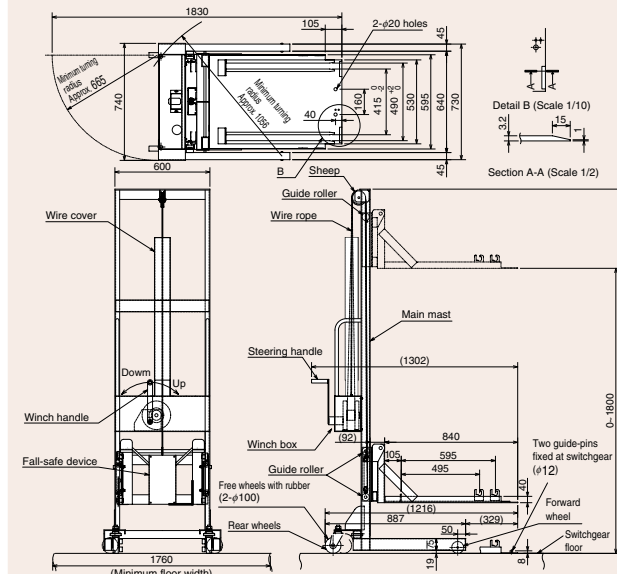

Figure 8.4 Testing cables

Lifter

Please make sure to specify the type and quantity when placing an order.

Type
F-2C



*The lifter is positioned at the correct place by setting pins on the switchgear. There are two holes (ϕ 20) for setting the pin positions.

Movable load: 1470N
Gross weight: 92kg

Figure 8.5 Lifter

Extension rail

Please make sure to specify the type and quantity when placing an order.

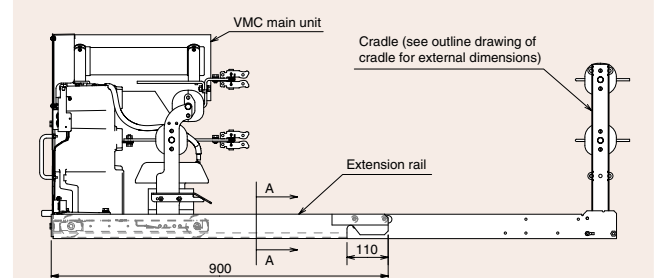
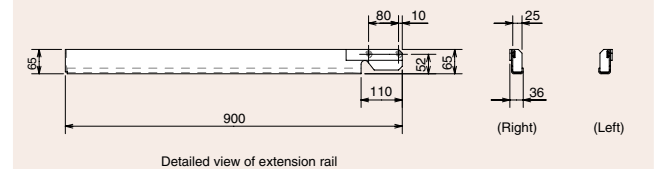
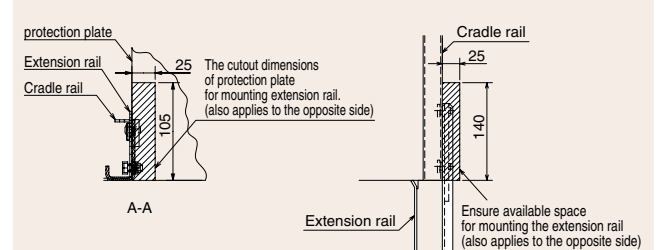

Figure 8.6 Extension rail

9 Principles and Methods of Operation

VMCs (contactor and combination units) are controlled through either continuous excitation or a mechanical latch mechanism. The features of these two mechanisms are described below to assist in the process of model selection. Both mechanisms have simple structures that use electromagnetic force, and are therefore suitable for applications involving multiple and frequent switching. Mitsubishi Electric's original control circuit is incorporated, making it possible to use either AC or DC power supplies.

Electrical hold

The VMC maintains its closing condition electrically utilizing electromagnetic force and continuous excitation of the holding coil. VMCs based on this mechanism have the following features:

- ① A simplified control circuit as the VMC can be turned on or off using the on/off signal.
- ② Since the closing condition is maintained by the electromagnetic force, the VMC is opened automatically when control power is lost. Accordingly, this mechanism is suitable for switching circuits to release load when control power is lost. However, please note that load is released even for power interruptions as short as 16ms.

Control circuit explanation Please refer to Fig. 9.1 for the circuit diagram.

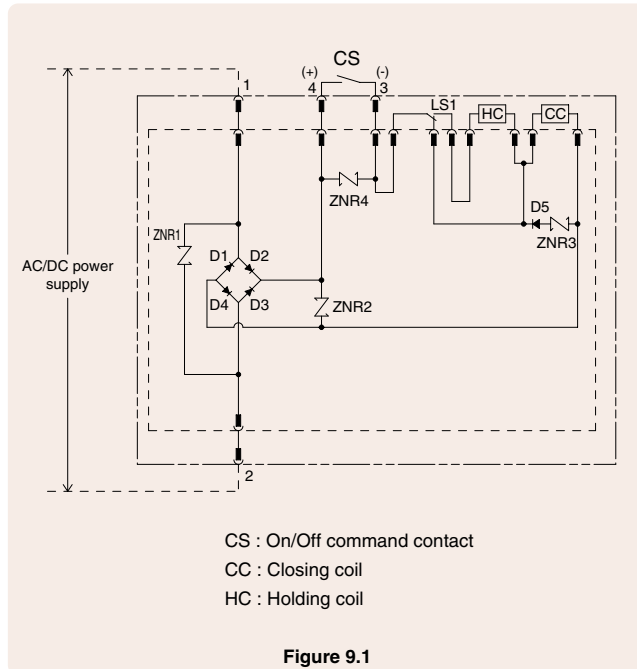

Figure 9.1

Closing operation

- ① When the on/off command contact (CS) is on, the current flowing in the closing coil (CC) closes the VMC.
- ② During this action, the limit switch (LS1) is switched and the holding current flows into the holding coil (HC) enabling the VMC to maintain a closing status.

Tripping operation

- ① The holding current is shutdown by turning the on/off command contact (CS) off, thereby tripping the VMC.

Mechanical latch mechanism

After completing the closing operation, the current flowing in the closing coil is automatically interrupted, but the magnetic force of the permanent magnet maintains the VMC at the closing status. VMCs using this mechanism have the following features:

- ① Energy savings and a compact power source device can be used as the control current only flows for a short period of time to energize the closing and tripping coils.
- ② The holding condition is maintained magnetically via the permanent magnet, even if the control power is interrupted. This mechanism is therefore suitable for switching circuits when load release is not desired in the case of a power interruption, including momentary interruptions.

When the VMC has to be tripped during an AC power interruption, the capacitor tripping device is available.

Control circuit explanation Refer to Figure 9.2 for the circuit diagram

Closing operation

- ① When the on command contact (CS1) is turned on, the current flows into the closing coil (CC), and closes the VMC. At this time, the movable core is attracted to the permanent magnet located on the fixed core side so that the VMC can maintain the holding status.
- ② During this action, the limit switch (LS1) is activated and the current flowing into the closing coil (CC) is shutdown to complete the closing operation.
- ③ Through the closing operation of the VMC, the auxiliary switch (52a) is turned on in preparation for the subsequent tripping operation.

Tripping operation

- ① When the off command contact (CS2) is turned on while the VMC is maintaining a holding status, the current flows into the tripping coil (TC) to cancel the magnetic force of the permanent magnet by creating magnetic flux in the direction opposite to that of the permanent magnet, enabling the VMC to be opened using the tripping spring force.
- ② At the same time the VMC is opened, the auxiliary switch (52a) is turned off to interrupt the tripping coil (TC) current.

Trip-free operation

If the on/off command contacts are applied at the same time the VMC has an open status, then:

- ① The closing operation is carried out following closing operation steps ① and ②. Subsequently, since the off command contact (CS2) continues, the tripping operation is carried out following tripping operation steps ① and ②.
- ② Even if CS1 is still on, the closing circuit cannot be created since the pumping prevention relay (52X) is continually energized. This keeps contact 52X-b open, and the VMC is maintained in the off status.

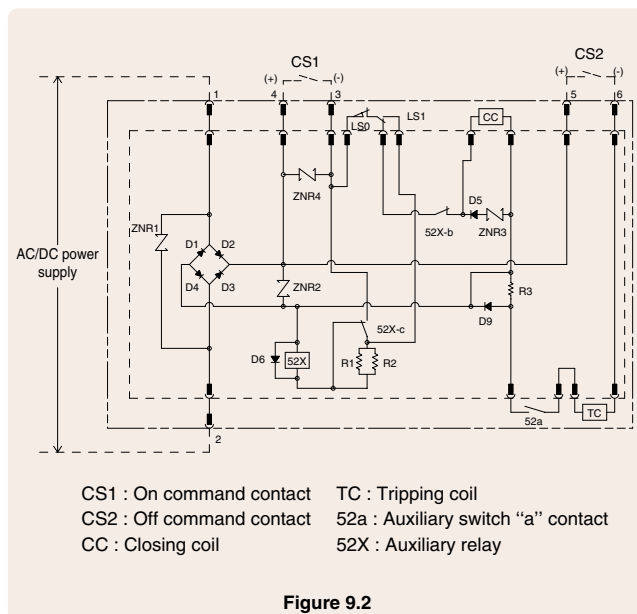
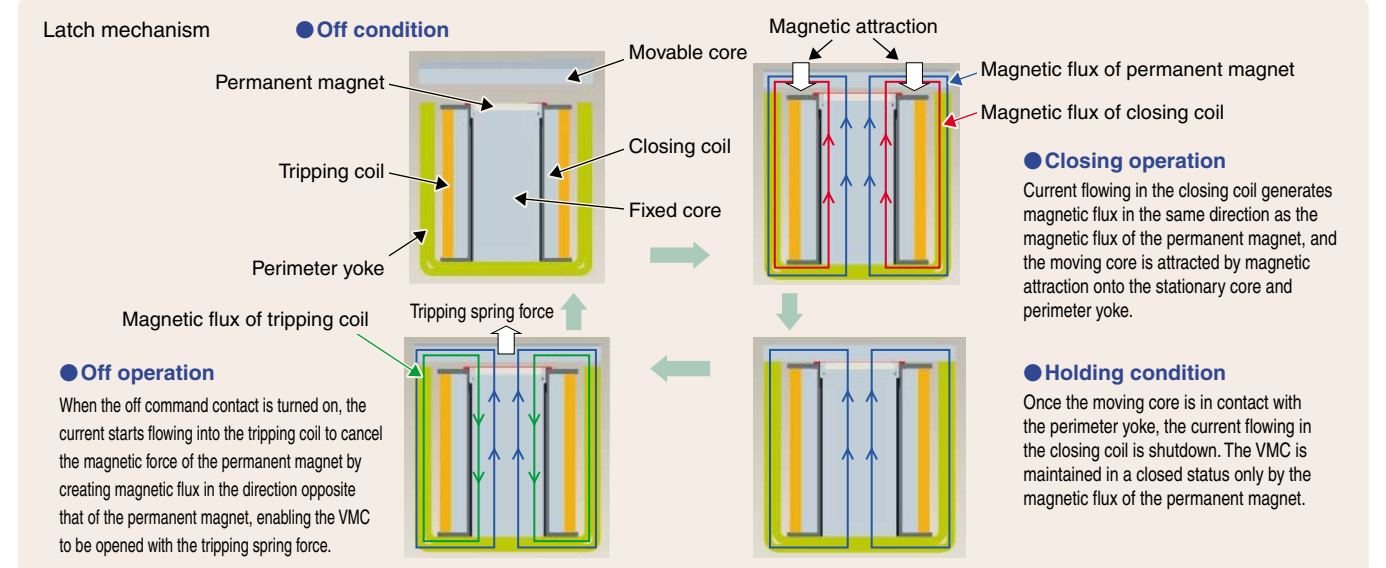

Figure 9.2

Principle of Operations



Control Current

Type	Operating method	Control voltage (V)	Closing current (between 3 and 4)		Tripping current (between 5 and 6)		Holding current (A)	
			I1 (A)	t (s)	I2 (A)	t (s)	Between 1-2	Between 3-4
VZ□-□E-E	Electrical hold	AC100	DC4.5	0.2	-	-	AC0.10	DC0.10
		DC100	DC4.5	0.2	-	-	DC0.07	DC0.07
		AC200	DC2.5	0.2	-	-	AC0.06	DC0.06
		DC200	DC2.5	0.2	-	-	DC0.04	DC0.04
VZ□-□L-E	Mechanical latch	AC100	DC4.5	0.2	DC2.0	0.05	-	-
		DC100	DC4.5	0.2	DC1.5	0.05	-	-
		AC200	DC2.5	0.2	DC1.5	0.05	-	-
		DC200	DC2.5	0.2	DC1.0	0.05	-	-

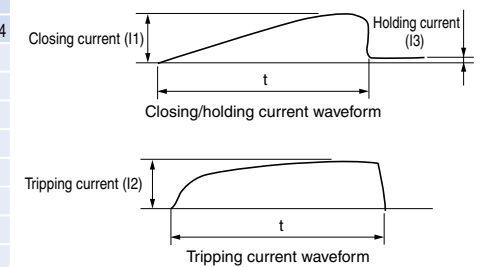

Temperature rise in closed/tripped coils

Coils are designed with short-term ratings to prevent an excessive increase in temperature during normal operation when closed or tripped. However, during irregular operation such as when a circuit in the VMC malfunctions or foreign matter has permeated the unit, the coil temperature may rise. The maximum current duration at that time is shown on the right.

Closing coil: 1min*
Tripping coil: 1min*
* When reaching a coil temperature of 80°C.

Tolerance Range of Operation Voltage Fluctuation

	Closing voltage	Opening voltage	Tripping voltage	Capacitor tripping voltage
Electrical hold		AC/DC 75~110%	-	-
Latch	AC/DC 85~110%	-	AC/DC 75~110% DC 70~110% (IEC60470)	AC75~110%

Precautions

Standard connection diagrams are shown on pages 14 and 15 for each model. Please observe the following precautions when using these products.

- ① **Connection to distribution switchgear**
Use a lead wire of standard accessory with connector (1.25m², yellow and 1.5m cable) to connect the VMC to the distribution switchgear.
- ② **Operational current for auxiliary circuit**
The operational current for equipment such as the auxiliary contact circuit and fuse melting detector contact circuit must be 1A or less.
- ③ **Making and tripping commands and their duration**
The C contact is available for closing and tripping commands for latched types. For pulse commands, please use a command time of 1s or longer.
- ④ **Recommended control relay**
The control relays below are recommended for the closing and tripping commands for latched types.
AC operation: Mitsubishi Electric Type-SR-N4 relay; DC operation: Mitsubishi Electric Type-SRD-N4 relay
For relays of other manufacturers, please make sure to select relays with a contact capacity equivalent to or larger than the capacities shown below.
• Current: 7A or larger
• Operating current: 0.10A or more for 100VDC } L/R = 100ms
0.06A or more for 200VDC }
- ⑤ **Control power supply**
Both the continuous excitation and latched models can be controlled by the 50VA voltage transformer (VT) (one VT is required for each VMC). Use of Mitsubishi Electric Type-PD-50HF VT for 50VA and Type-PD-100HF VT for 100VA is recommended.
- ⑥ **Capacitor tripping**
Please make sure to comply with the connection diagram so that the off contact is connected at the proper location and the power cable is connected with proper polarity (+/-). If the power cable is connected with improper

polarity or the off contact is connected to the negative (-) side, capacitor tripping will not operate properly. It takes approximately 10s for KF-100E, and 5s for KF-200E to fully charge. If the open command is applied before completing the charge, the VMC will not open and the circuit may burn out. The VMC can be tripped within 30s after power interruption by the residual electric charge in the capacitor.

- ⑦ **Control circuit protection (protecting the control coil from burnout)**
Mitsubishi Electric CP-30BA circuit protectors can protect circuits from burnout in the case of continuous excitation of the coil, which may be caused by a failure in the control circuit.
Recommended circuit protector: Mitsubishi Electric CP-30BA circuit protector (medium speed)

Operating method	Control voltage	Power supply	Off command section (between terminal Nos. 5 and 6)
Electrical hold	100V	Rated current 2A*1	-
	200V	Rated current 1A*1	-
Mechanical latch	100V	Rated current 2A*1	Rated current 1A (two-pole series)
	200V	Rated current 1A*1	Rated current 0.5A (two-pole series)

*1: One-pole for AC power supply and 2-pole for DC power supply

- ⑧ **Withstand voltage of control circuit**
The withstand voltage (between ground and all terminals) of the control circuit is 2kV (AC) and 7kV (impulse). Make sure to check these voltages during withstand voltage testing.
Excessive voltage or improper connection may cause a failure in the circuit.
- ⑨ **Successive switching operations**
As the switching frequency is 600 times per hour, successive switching of less than every 6s is not possible.

Application to Special Environments

Operating environment

VZ-E Series vacuum contactors and combination units are indoor units that comply with JEM1167: "High-voltage AC Electromagnetic Contactors (2007)" and IEC60470: "High-voltage alternating current contactors and contactor-based motor-starters (2000)." These devices should be operated within the standard operating environments listed in Table 10.1. For operation in environments other than standard environments, special consideration for the switchgear side is required. Please contact a Mitsubishi Electric representative for further information.

Installation site and ambient atmosphere

Special measures against dust, corrosion, water and condensation are required for operation of the contactors/units in outdoor environments or environments where elements such as dust or corrosive gas are present.

Surge Protector Application

Introduction of low-surge vacuum interrupter

Since a low-surge vacuum interrupter is used for the VZ-E Series VMCs it can be used with a low ON/OFF surge voltage without surge protection except in the following case.

Surge protection requirements

The surge protection requirements against switching are listed in Table 10.2. Use of the CR suppressor is recommended for motor inching operation or when using older existing motors.

Table 10.2 Surge protection requirements for VZ-E Series VMCs

Load	Motor	Dry transformer	Mitsubishi Electric mold transformer and oil-immersed transformer	Capacitor
Surge protection requirements	Not required*1	Not required	Not required	Not required

*1: For frequent motor inching operations or switching using older existing model motors, please use the CR suppressor.
Note: Inching (energizing a motor or solenoid repeatedly for short periods to obtain small movements of the driven mechanism)
*VMC: Vacuum electromagnetic contactor

Endurance

VMC endurance depends on the vacuum strength of the valve, electrical ON/OFF endurance, mechanical ON/OFF endurance, and other factors related to deterioration.

Durability of vacuum strength

The breaking and insulation performance of our VMCs is ensured by the high vacuum strength of the vacuum switch tube. Before shipment from the factory, a 100% check is performed for the vacuum strength of valves to ensure the ability of long-term use. The vacuum strength of vacuum switch tubes can be easily tested during periodical inspections using the withstand voltage method. In addition, a portable vacuum checker is optionally available at your request. (See page 21)

Electrical ON/OFF endurance

The electrical ON/OFF durability of the vacuum switch tube is determined by the electrode consumption and load ON/OFF frequency. Since the electrode consumption of the VZ-D type VMC due to ordinary load ON/OFF is extremely small, it is possible to control the endurance with the ON/OFF frequency. In terms of electrical ON/OFF endurance, 250,000 times is defined for the normal loads for motors and transformers, while 100,000 times is defined for capacitor loads.

Table 10.1 Operating environments

Standard operating conditions (excerpt from JEM1167)

Environments where:

1. Altitude is 1,000m or less
2. Ambient temperature is between -5 and 40°C (the average temperature for 24 hours must not exceed 35°C).
3. Relative humidity is between 45% and 85%.
4. There are no abnormal vibrations or shocks
5. Elements such as excessive water/oil vapor, smoke, dust, salt and corrosive substances are not present.
6. There is no condensation due to changes in temperature and humidity when installed in an outdoor switchgear.

Example of surge protector application

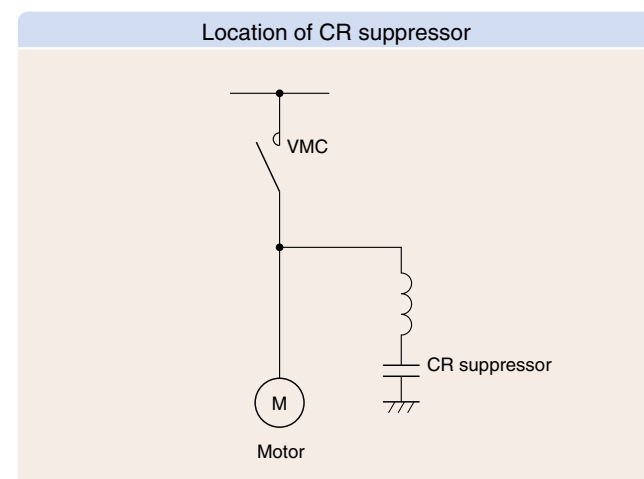

Mechanical ON/OFF endurance

The mechanical ON/OFF frequency can be controlled by the 6-digit operation counter (optional) mounted on the VMC. The mechanical ON/OFF endurance of vacuum switch tube is 250,000 times.

Deterioration stress endurance

Please note that VMCs will deteriorate even when used under normal conditions. For correct use of VMC, daily and periodical maintenance is requested. Please follow the instruction manual for details on lubrication and cleaning.

Recommended replacement time

To ensure that the VMCs function properly and continue highly reliable operation, replacement within 15 years from the staff of operations or within the above-mentioned ON/OFF endurance frequency is recommended.

Cautions For VMC Application

Application to capacitor circuit

① Cautions regarding inrush current

If the capacitor installed is rated higher than 300kVar (at 6.6kV) or 150kVar (at 3.3kV), install a 6% - 13% series reactor to protect against the effect of inrush current. If another capacitor circuit is used in parallel, be sure to install a series reactor.

② Capacitor recharging interval

Recharging a capacitor that still maintains an electrical charge may generate excessive voltage. To avoid this, please allow sufficient time for the capacitor charge to dissipate.

③ If there is a parallel capacitor circuit

The maximum application capacity should be reduced for use. For selection of a power fuse, refer to the power fuse catalogue.

④ ON/OFF durability of capacitor

The standard for ON/OFF durability in terms of capacitor ON/OFF current is shown in the following chart. VMC needs to be used within the specified frequency and to carry out the maintenance according to the instruction manual.

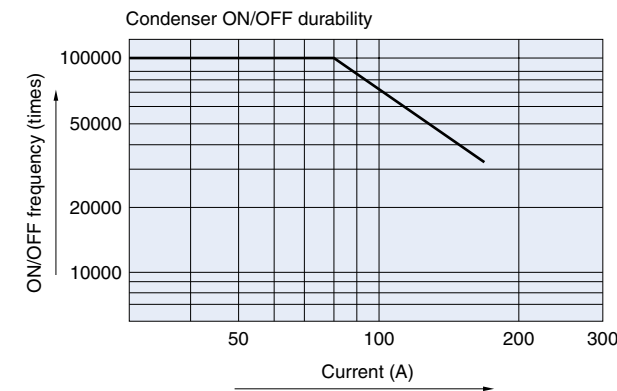

Note: 1. The chart shows the values for 6% ~ 13% series reactor.
2. The values indicated are without a parallel capacitor circuit.
3. Use in a parallel capacitor circuit will result in a shorter life than capacitor circuit shown in the chart.

Application to three-phase motor circuit

Please use the table below to select an appropriate model for application to non-reciprocal and reciprocal circuits. For reciprocal circuits, please be careful when selecting the VMC and surge protector.

		Operational voltage	
		3kV	6kV
Non-reciprocal circuit	Without inching operation	· Select VZ2/VZ4-E VMC	· Select VZ2/VZ4-E VMC
	With inching operation	· Select VZ2/VZ4-E VMC Note: Surge protector (CR-3) is required.	· Select VZ2/VZ4-E VMC Note: Surge protector (CR-6) is required.
Reciprocal circuit	Without plugging or inching operation	· Select VZ2/VZ4-E VMC · The switching durability is limited to 250,000 times Note: Surge protector (CR-3) is required.	-
	With plugging and inching operation	· Select VZ2-E VMC · The maximum switching current: making current is 750Ap /breaking current is 300Arms. · The interval from normal and to reverse rotations, and vice versa must be 0.4s or longer. · The endurance is limited to 100,000 times. Note: Surge protector (CR-6) is required.	-

*Please contact a Mitsubishi Electric representative for more information regarding VZ-M/D VMCs.

⑤ Operation using an automatic power-factor regulator

When using an automatic power-factor regulator with the VMC, improper set-up may cause trouble in the form of repeated unnecessary and excessive switching operations. Please ensure that the regulator is set-up correctly.

Do not use the VMC together with different power systems

As the inter-electrode withstand voltage of the VMC is lower than the voltage of a VCB, VMCs are not to be used in the power generation equipment of commercial or other power generation facilities, where voltages are applied between electrodes.

Application to Condolfer start circuit

When a motor is driven by auto-transfer (Condolfer start), the neutral point in the auto-transformer is opened only after the starting current is sufficiently damped. Do not open the neutral point in the auto-transformer before the starting current is damped. In selecting the auto-transformer to be used in a starting compensator, make sure to use the Condolfer starting transformer as specified: "Special Transformers."

Insulation

Our VZ2/VZ4-E Series VMCs are in compliance with IEC60470, and it has been confirmed that they can withstand impulse voltages between the in-phase poles up to ±40kV. For applications requiring 60kV impulse withstand voltage between poles, we recommend the use of VCB.

Polarity in connecting to main circuit

When connecting the combination unit, make sure to connect the upper terminals to the power supply side so that the power fuse can protect a wider range. However, please note that the contactor can be connected to the power supply side or load side; electric and mechanical performance will be the same.

11 Placing an Order

When placing an order, please specify the specification number in the format shown below.

Fixed-type vacuum contactor (VZ-E)

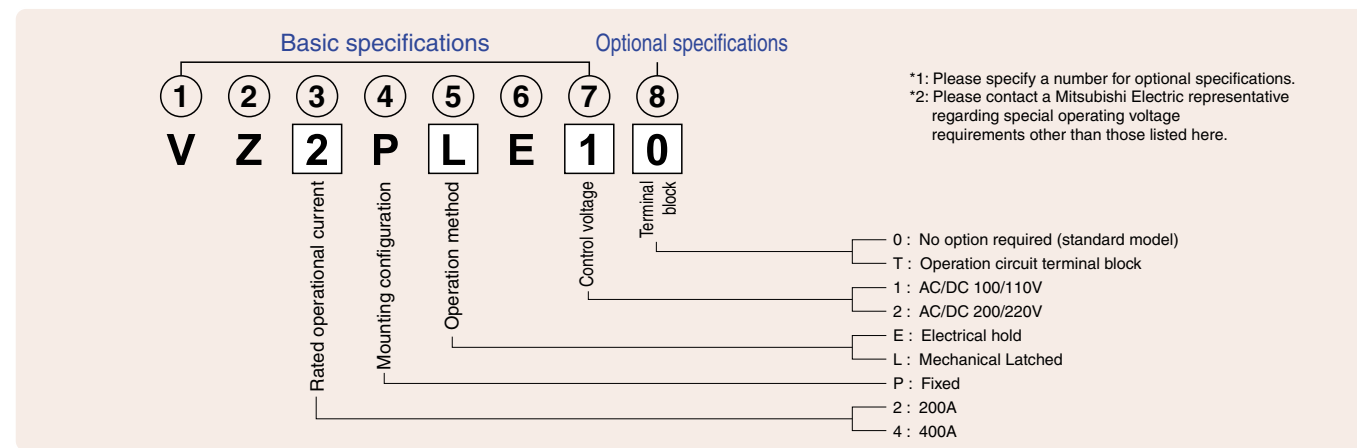

Vacuum Combination Unit (VZ-E)

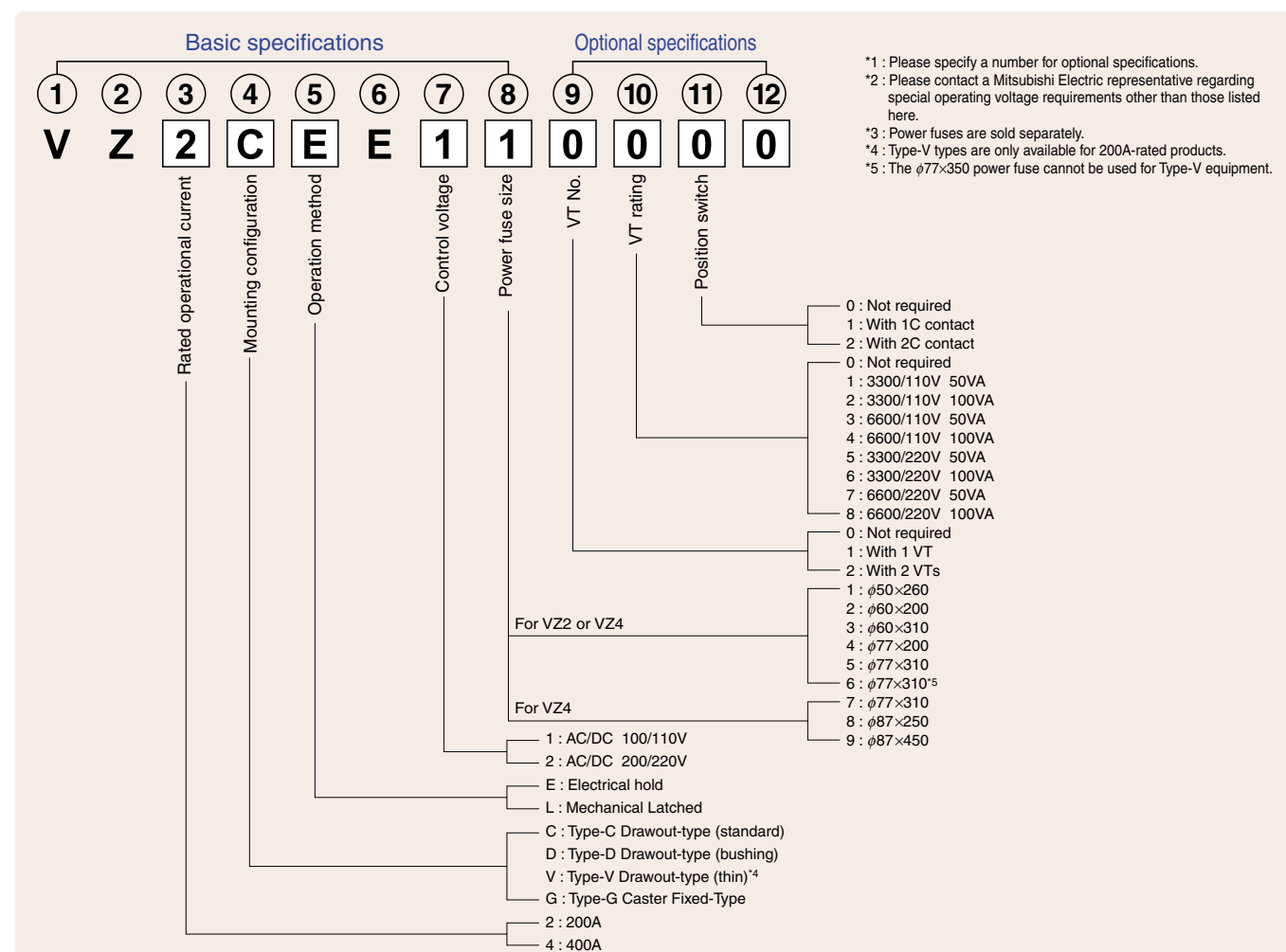

*Please contact a Mitsubishi Electric representative regarding the Type-D cradle, Protection grade IP3X.

Power fuse size

Code No.	Size		Power fuse type/rating			Code No.	Size		Power fuse type/rating		
	Diameter (mm)	Length (mm)	Type	Type code	Rated voltage/current (G/M rating)		Diameter (mm)	Length (mm)	Type	Type code	Rated voltage/current (G/M rating)
1	50	260	CL	LB	3.6kV : G5-G75	4	77	200	CLS	R	3.6kV : M150-M200
					7.2kV : G5-G75						7.2kV : G150-G200
2	60	200	CLS	R	3.6kV : M20-M100	6	77	350	CLS	R	7.2kV : M100-M200 ⁵
					3.6kV : G75-G200						3.6kV : G300-G400
3	60	310	CL	-	7.2kV : G75-G100	7	77	310	CL	-	3.6kV : M300-M400
					7.2kV : M20-M50						7.2kV : M300-M400

⁵For codes 7-9, combination with VZ4 is required.

Drawout-type Vacuum Contactor (VZ-E)

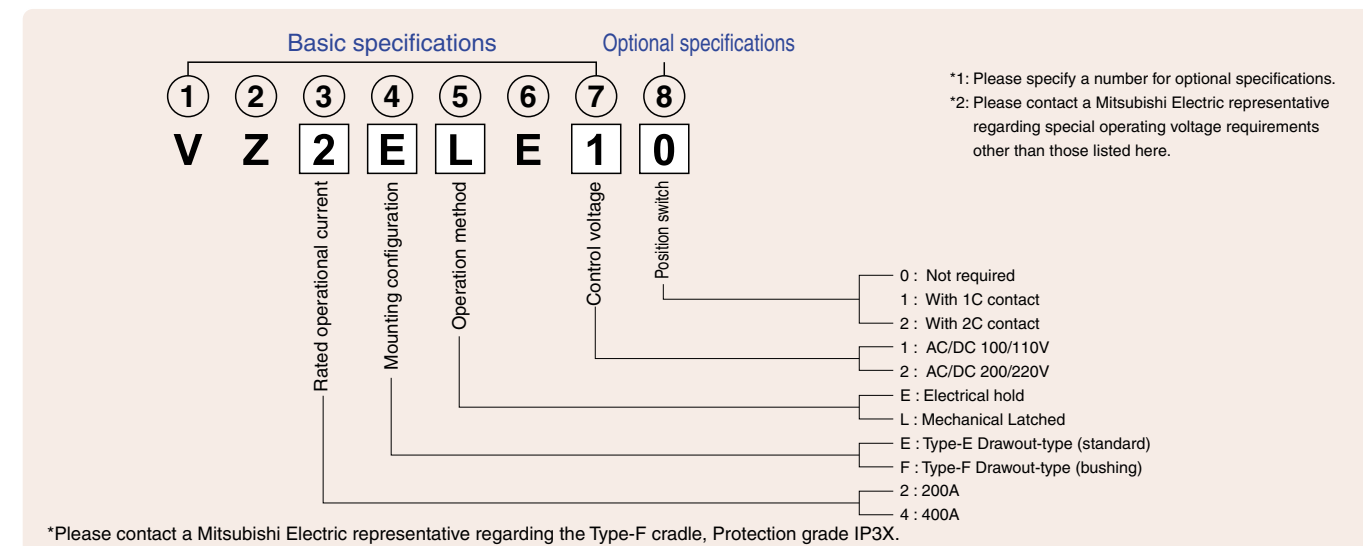

*Please contact a Mitsubishi Electric representative regarding the Type-F cradle, Protection grade IP3X.

Parts modified due to changes in power fuse specifications

No.	⑧ Power fuse size (Code No.)		Parts modified	No.	⑧ Power fuse size (Code No.)		Parts modified
	Before change	After change			Before change	After change	
1	1	2	PF clamp, rating/PF/code nameplates	26	6	1	PF clamp, rating/PF/code nameplates
2	1	3	PF clamp, rating/PF/code nameplates	27	6	2	PF clamp, rating/PF/code nameplates
3	1	4	PF clamp, rating/PF/code nameplates	28	6	3	PF clamp, rating/PF/code nameplates
4	1	5	PF clamp, rating/PF/code nameplates	29	6	4	Rating/PF/code nameplates
5	1	6	PF clamp, rating/PF/code nameplates	30	6	5	Rating/PF/code nameplates
6	2	1	PF clamp, rating/PF/code nameplates	31	7	1	PF clamp, rating/PF/code nameplates
7	2	3	Rating/PF/code nameplates	32	7	2	PF clamp, rating/PF/code nameplates
8	2	4	PF clamp, rating/PF/code nameplates	33	7	3	PF clamp, rating/PF/code nameplates
9	2	5	PF clamp, rating/PF/code nameplates	34	7	4	Rating/PF/code nameplates
10	2	6	PF clamp, rating/PF/code nameplates	35	7	5	Rating/PF/code nameplates
11	3	1	PF clamp, rating/PF/code nameplates	36	7	6	Rating/PF/code nameplates
12	3	2	Rating/PF/code nameplates	37	7	8	PF clamp, rating/PF/code nameplates
13	3	4	PF clamp, rating/PF/code nameplates	38	8	1	PF clamp, rating/PF/code nameplates
14	3	5	PF clamp, rating/PF/code nameplates	39	8	2	PF clamp, rating/PF/code nameplates
15	3	6	PF clamp, rating/PF/code nameplates	40	8	3	PF clamp, rating/PF/code nameplates
16	4	1	PF clamp, rating/PF/code nameplates	41	8	4	PF clamp, rating/PF/code nameplates
17	4	2	PF clamp, rating/PF/code nameplates	42	8	5	PF clamp, rating/PF/code nameplates
18	4	3	PF clamp, rating/PF/code nameplates	43	8	6	PF clamp, rating/PF/code nameplates
19	4	5	Rating/PF/code nameplates	44	8	7	PF clamp, rating/PF/code nameplates
20	4	6	Rating/PF/code nameplates	45	9	6	PF clamp, rating/PF/code nameplates
21	5	1	PF clamp, rating/PF/code nameplates				
22	5	2	PF clamp, rating/PF/code nameplates				
23	5	3	PF clamp, rating/PF/code nameplates				
24	5	4	Rating/PF/code nameplates				
25	5	6	Rating/PF/code nameplates				

*Modifications can be performed at a Mitsubishi Electric service center. Please contact a Mitsubishi Electric office, agent or service center regarding your modification requirements.

Handwriting practice area on page 28, consisting of 25 horizontal dashed lines.

Handwriting practice area on page 29, consisting of 25 horizontal dashed lines.